



SENTADO

PANDA FUTURA

Supace

CUADRO DE MEDIDAS

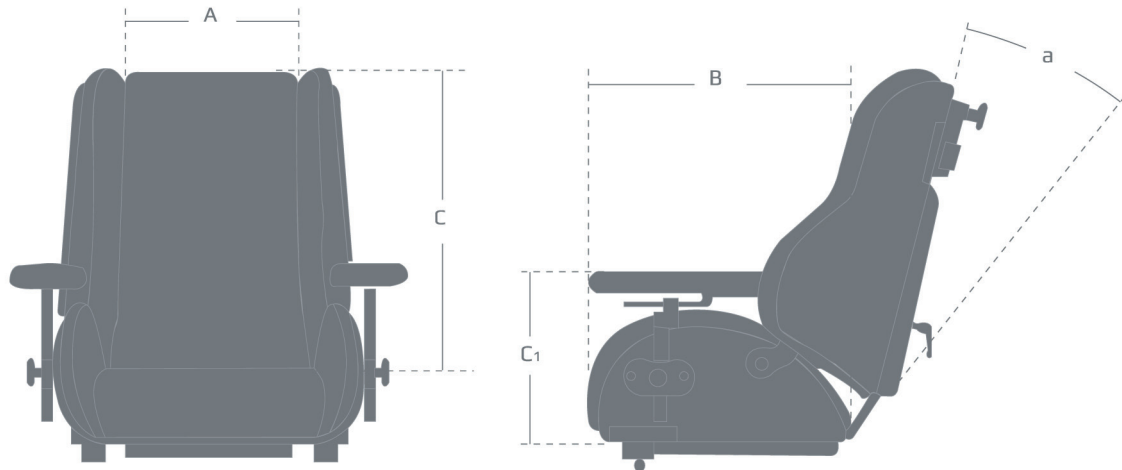

Medidas

PANDA FUTURA

	Profundidad de lasiento (A)	Ancho de lasiento (B)	Altura del respaldo (C)	Altura del reposabrazos (C1)	Peso	Carga máxima	Carga máxima en vehículo	Ángulo del respaldo (a)
Panda active, talla 2	24 (9¼")	22 (8½")	35 (13¾")	13-18 (5-7")	5,2 (11,5 lb)	50 (110 lb)	-	-4°- +27°
Panda active, talla 2½	28 (11")	25 (9¾")	38 (14¾")	13-18 (5-7")	5,6 (12,5 lb)	50 (110 lb)	-	-10°- +20°
Panda active, talla 3	31 (12")	29 (11¼")	40 (15½")	13-27 (5-10½")	6,2 (13,5 lb)	50 (110 lb)	-	-9°- +27°
Panda active, talla 4	36 (14")	32 (12½")	45 (17½")	17-30 (6¾-1¾")	7,5 (16,5 lb)	60 (132 lb)	-	-6°- +17°
Panda Standard, talla 1	22 (8½")	22 (8½")	29 (11¼")	13-18 (5-7")	5,7 (12,5 lb)	50 (110 lb)	27 kg (59,5 lb)	-3°- +28°
Panda Standard, talla 2	24 (9¼")	22 (8½")	39 (15¼")	13-18 (5-7")	5,7 (12,5 lb)	50 (110 lb)	27 kg (59,5 lb)	-15°- +32°
Panda Standard, talla 2½	28 (11")	25 (9¾")	41 (16")	13-18 (5-7")	6,2 (13,5 lb)	50 (110 lb)	43 kg (94,5 lb)	-10°- +35°
Panda Standard, talla 3	31 (12")	29 (11¼")	44 (17¼")	13-27 (5-10½")	7,3 (16 lb)	50 (110 lb)	43 kg (94,5 lb)	-5°- +36°
Panda Standard, talla 4	36 (14")	32 (12½")	52 (20¼")	18-27 (7-10½")	8,7 (19 lb)	60 (132 lb)	43 kg (94,5 lb)	-5°- +30°